

KFC-HQP40

SERVICE MANUAL

KENWOOD

© 1994-7 PRINTED IN JAPAN
B51-6739-00 (N) 327

EXTERNAL VIEW

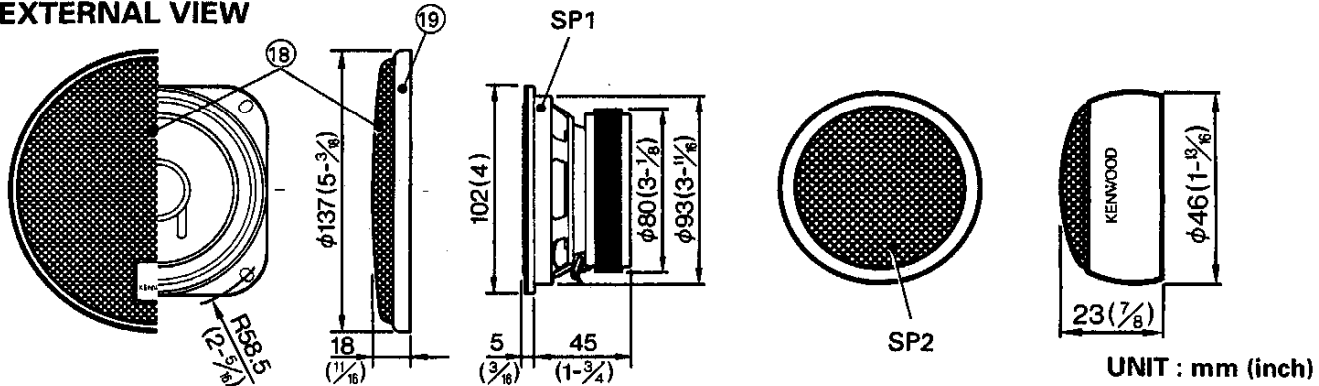

UNIT : mm (inch)

PARTS INCLUDED

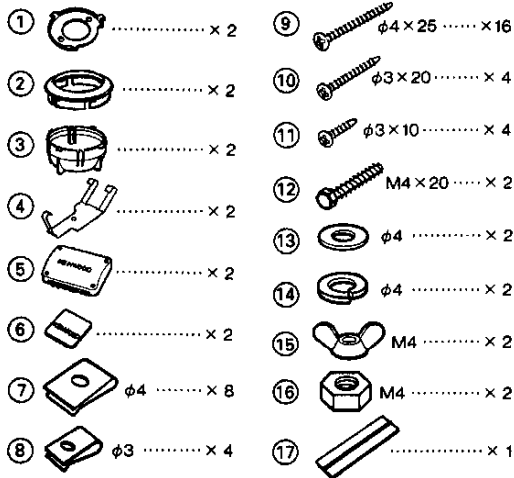

SPECIFICATIONS

Speakers
 Midrange _____ 100mm (4in) Injection P.P.
 Cone Type 227g (8 oz) Magnet
 Tweeter _____ 25mm (1in) Dome Type
 Peak Power _____ 150Watts
 Frequency Response _____ 50Hz~26,000Hz
 Sensitivity _____ 88dB/W at 1m
 Impedance _____ 4 Ohms
 Net Weight With Grille
 Midrange _____ 1,360g (3.0lb)/Pair
 Tweeter _____ 120g (4.2 oz)/Pair
 Passive Crossover Network
 Crossover Frequency _____ 4,000Hz

TECHNICAL SPECIFICATIONS

	SIMBOL	UNIT	VALUE
MIDRANGE			
Nominal Impedance	Z	ohms	4
DC Resistance	RE	ohms	3.40
Voice Coil Inductance	LBM	μH	0.14 × 10 ³
Resonant Frequency	Fso	Hz	120
Resonant Frequency Impedance	Zso	ohms	27.38
Mechanical Q Factor	Qms		4.570
Electrical Q Factor	Qes		0.661
Total Q Factor	Qts		0.567
Volume Acoustic Compliance	Vas	liters	1.55
		(cu.ft.)	(0.055)
Mechanical Resistance	Rms	kg/s	0.848
Moving Mass	Mms	g	5.18
Suspension Compliance	Cms	mm/N	0.448 × 10 ⁻³
Emissive Diameter of the Diaphragm	D	mm	80.5
Voice Coil Diameter	d	mm	25.38
Voice Coil Layers	n		2
Flux Density	B	T	1.104
Force Factor	BL	T·m	4.271
Diameter of Magnet	A	mm	80
Weight of Magnet	MAGWeight	kg	0.227
Total Flux	Φ	Wb	4.03 × 10 ⁻⁴
Peak Exclusion	Xmas	mm	1.1
TWEETER			
Nominal Impedance	Z	ohms	4
DC Resistance	RE	ohms	3.60
Voice Coil Inductance	LBM	μH	0.23 × 10 ³
Emissive Diameter of the Diaphragm	D	mm	29
Voice Coil Diameter	d	mm	25.43
Voice Coil Layers	n		2
Flux Density	B	T	1.100
Diameter of Magnet	A	mm	23.5
Weight of Magnet	M	kg	0.011
Total Flux	Φ	Wb	1.75 × 10 ⁻⁴

PARTS LIST

* New Parts
 Parts without Parts No. are not supplied.
 Les articles non mentionnés dans le Parts No. ne sont pas fournis.
 Teile ohne Parts No. werden nicht geliefert.

Ref No.	New Parts	Parts No.	Description
①	*	J21-8201-08	Hardware (A)
②	*	J21-8199-08	Bracket (A)
③	*	J21-8200-08	Bracket (B)
④	*	J21-8202-08	Hardware (B)
⑤	*	L75-2052-08	Network
⑥	*	B43-0937-08	Badge set
⑦~⑯	*	N99-1285-08	Screw set
⑰	*	J69-0117-08	Viscous tape
⑱	*	F09-1097-08	Protector
⑲	*	B06-0885-08	Grille
SP1	*	T06-0330-08	Mid-range
SP2	*	T03-0482-08	Tweeter

KENWOOD follows a policy of continuous advancements in development.
 For this reason specifications may be changed without notice.